

**Luftheizgeräte
Air Heaters
Luchtverwarmingssystemen**

**Einbauanweisung
Installation Instructions
Montagehandleiding**

Air Top 2000 ST

Handelsbezeichnungen/Trade names/Handelsnamen:

Air Top 2000 ST B (Benzin/Petrol/benzine)

Air Top 2000 ST D (Diesel/PMU)

**05/2008
9010298C**



Das unsachgemäße Einbauen oder Reparieren von Webasto Heiz- und Kühlsystemen kann Feuer verursachen oder zum Austritt von tödlichem Kohlenmonoxid führen. Dadurch können schwere oder tödliche Verletzungen hervorgerufen werden.

Für den Einbau und die Reparatur von Webasto Heiz- und Kühlsystemen bedarf es eines Webastotrainings, technischer Dokumentation, Spezialwerkzeuge und einer Spezialausrüstung.

Versuchen Sie NIEMALS, Webasto Heiz- oder Kühlsysteme einzubauen oder zu reparieren, wenn Sie das Webastotraining nicht erfolgreich abgeschlossen und dabei die notwendigen technischen Fähigkeiten erworben haben und die für einen sachgerechten Einbau und Reparatur nötigen technischen Dokumentationen, Werkzeuge und Ausrüstungen nicht zur Verfügung stehen.

Befolgen Sie IMMER alle Webasto Einbau- und Reparaturanleitungen, und beachten Sie alle Warnhinweise.

Webasto übernimmt keine Haftung für Mängel und Schäden, die auf einen Einbau durch ungeschultes Personal zurückzuführen sind.



Improper installation or repair of Webasto heating and cooling systems can cause fire or the leakage of deadly carbon monoxide leading to serious injury or death.

To install and repair Webasto heating and cooling systems you need to have completed a Webasto training course and have the appropriate technical documentation, special tools and special equipment.

NEVER try to install or repair Webasto heating or cooling systems if you have not completed a Webasto training course, you do not have the necessary technical skills and you do not have the technical documentation, tools and equipment available to ensure that you can complete the installation and repair work properly.

ALWAYS carefully follow Webasto installation and repair instructions and heed all WARNINGS.

Webasto rejects any liability for problems and damage caused by the system being installed by untrained personnel.

Inhaltsverzeichnis

1	Gesetzliche Bestimmungen für den Einbau	1
2	Verwendung der Luftheizgeräte	4
3	Einbau	5
4	Fabrikschild	8
5	Einbaubeispiel	9
6	Heizluftsystem	10
7	Brennstoffversorgung	12
8	Brennluftversorgung	17
9	Abgasleitung	18
10	Brennluftansaug- und Abgasleitungen	19
11	Elektrische Anschlüsse	21
12	Legende für Schaltpläne	29
13	Erstinbetriebnahme	31
14	Störabschaltung	32
15	Technische Daten	34
16	Ausführung	36
17	Bohrschablone	37

Table of contents

1	Statutory regulations governing installation	39
2	Use of the air heaters	42
3	Installation	43
4	Factory plate	46
5	Installation example	47
6	Hot air system	48
7	Fuel supply	50
8	Combustion air supply	55
9	Exhaust pipe	56
10	Combustion air inlet and exhaust lines	57
11	Electrical connections	59
12	Legend for circuit diagrams	67
13	Initial start-up	69
14	Fault lock-out	70
15	Technical data	72
16	Version	74
17	Drilling template	75

1 Statutory regulations governing installation

1.1. Statutory regulations governing installation

The Air Top 2000 ST heater unit has been type- tested and approved in accordance with Directives 72/245/EEC (EMC), 2001/56/EC (heater) and ECE R122 with the following permit numbers:

e1*72/245*95/54*1085*00
e1*2001/56*0022*00
E1*R122 00 0216*--

Primarily the regulations of Annex VII of the Directive 2001/56/EG and Part 2 or Annex 7 of the directive ECE R122 must be observed for the installation.

NOTE:

The provisions of these Directives are binding within the territory governed by EU Directive 70/156/EEC and should similarly be observed in countries without specific regulations.

IMPORTANT

Failure to follow the installation instructions and the notes contained therein will lead to all liability being refused by Webasto. The same applies if repairs are carried out incorrectly or with the use of parts other than genuine spare parts. This will result in the invalidation of the type approval for the heater and therefore of its *homologation / EC/ECE type licence*.

(Extract from Directive 2001/56/EC Annex VII and ECE R122 Part 2 and Annex 7)

1.7.1. / 7.1. A clearly visible tell-tale in the operator's field of view shall inform when the combustion heater is switched on or off.

2. / 5.3. Vehicle installation requirements

2.1. / 5.3.1. Scope

2.1.1. / 5.3.1.1. Subject to paragraph 2.1.2 / 5.3.1.2 combustion heaters shall be installed according to the requirements of this Annex/Article.
2.1.2 / 5.3.1.2. Vehicles of category O (trailers) having liquid fuel heaters are deemed to comply with the requirements of this Annex/Article.

2.2. / 5.3.2. Positioning of heater

2.2.1. Body sections and any other components in the vicinity of the heater must be protected from excessive heat and the possibility of fuel or oil contamination.
2.2.2 / 5.3.2.2. The combustion heater shall not constitute a risk of fire, even in the case of overheating. This requirement shall be deemed to be fulfilled if the installation ensures an adequate distance to all parts and suitable ventilation, by the use of fire resistant materials or by the use of heat shields.
2.2.3 / 5.3.2.3. In the case of M2 and M3 vehicles, the heater must not be positioned in the passenger compartment. However, an installation in an effectively sealed envelope which also complies with the conditions in paragraph 2.2.2 / Article 5.3.2.2 may be used.

2.2.4 / 5.3.2.4. The label referred to in paragraph 1.4 / annex 7 / article 1.4 (model plate), or a duplicate (duplicate model plate), must be positioned so that it can be easily read when the heater is installed in the vehicle.

2.2.5 / 5.3.2.5 Every reasonable precaution should be taken in positioning the heater to minimise the risk of injury and damage to personal property.

2.3. / 5.3.3. Fuel supply

2.3.1 / 5.3.3.1. The fuel filler must not be situated in the passenger compartment and must be provided with an effective cap to prevent fuel spillage.

2.3.2 / 5.3.3.2. In the case of liquid fuel heaters, where a supply separate to that of the vehicle is provided, the type of fuel and its filler point must be clearly labelled.

2.3.3 / 5.3.3.3. A notice, indicating that the heater must be shut down before refuelling, must be affixed to the fuelling point. In addition a suitable instruction must be included in the manufacturer's operating manual.

2.4. / 5.3.4. Exhaust system

2.4.1 / 5.3.4.1. The exhaust outlet must be located so as to prevent emissions from entering the vehicle through ventilators, heated air inlets or opening windows.

2.5. / 5.3.5. Combustion air inlet

2.5.1 / 5.3.5.1. The air for the combustion chamber of the heater must not be drawn from the passenger compartment of the vehicle.

2.5.2 / 5.3.5.2. The air inlet must be so positioned or guarded that blocking by rubbish or luggage is unlikely.

2.6. / 5.3.6. Heating air inlet

2.6.1 / 5.3.6.1. The heating air supply may be fresh or recirculated air and must be drawn from a clean area not likely to be contaminated by exhaust fumes emitted either by the propulsion engine, the combustion heater or any other vehicle source.

2.6.2 / 5.3.6.2. The inlet duct must be protected by mesh or other suitable means.

2.7. / 5.3.7. Heating air outlet

2.7.1 / 5.3.7.1. Any ducting used to route the hot air through the vehicle must be so positioned or protected that no injury or damage could be caused if it were to be touched.

2.7.2 / 5.3.7.2. The air outlet must be so positioned or guarded that blocking by rubbish or luggage is unlikely.

2.8. / 5.3.8.1. Automatic control of the heating system

The heating system must be switched off automatically and the supply of fuel must be stopped within five seconds when the vehicle's engine stops running. If a manual device is already activated, the heating system can stay in operation.

NOTE:

Contrary to point 2.2.3 / 5.3.2.3 the heater must also not be installed in the passenger cabin of class M1 and N vehicles. However, an installation in an effectively sealed envelope which also complies with the conditions in paragraph 2.2.2 / section 5.3.2.2 may be used.

(Extract from Directive 2001/56/EC Annex IX)

3. Technical specifications for heater units for installation in dangerous goods transporters (Annex 9)

3.1. General (EX/II, EX/III, AT, FL and OX vehicles)

3.1.1. The combustion heaters and their exhaust gas routing shall be designed, located, protected or covered so as to prevent any unacceptable risk of heating or ignition of the load. This requirement shall be considered as fulfilled if the fuel tank and the exhaust system of the appliance conform to the provisions set out in the points 3.1.1.1 and 3.1.1.2. Compliance with those provisions shall be verified on the completed vehicle.

3.1.1.1. Any fuel tanks for supplying the appliance shall meet the following requirements:

- a) in the event of any leakage, the fuel shall drain to the ground without coming into contact with hot parts of the vehicle or the load;
- b) fuel tanks containing petrol shall be equipped with an effective flame trap at the filler opening or with a closure enabling the opening to be kept hermetically sealed.

3.1.1.2. The exhaust system as well as the exhaust pipes shall be so directed or protected to avoid any danger to the load through heating or ignition. Parts of the exhaust system situated directly below the fuel tank (diesel) shall have a clearance of at least 100 mm or be protected by a thermal shield.

3.1.2. The combustion heater shall be switched on manually. Programming devices shall be prohibited.

3.2. EX/II and EX/III vehicles

Combustion heaters using gaseous fuels are not permitted.

3.3. FL vehicles

3.3.1. The combustion heaters shall be put out of operation by at least the following methods:

- a) intentional manual switching off from the driver's cab;
- b) stopping of the vehicle engine; in this case the heating device may be restarted manually by the driver;
- c) start-up of a feed pump on the motor vehicle for the dangerous goods carried.

2 Use of the air heaters

The Webasto Air Top 2000 ST air heaters are designed

- to heat cabins, boats, trucks, minibuses, vans and motorhomes
- to defrost vehicle windows

The heaters operate independently of the engine and are connected to the fuel tank and the electrical system of the vehicle.

They may be used for vehicles with either water or air-cooled engines.

They are not designed for heating hazardous substances.

3 Installation

IMPORTANT

The statutory regulations governing installation on pages 1 and 2 must be adhered to. The requirements of the latest version of the ADR must also be observed for the installing the heater into vehicles used to transport hazardous substances.

The heater must not be operated without the control unit cover (this will cause the heater to overheat).

3.1. Air Top 2000 ST installation situation

NOTE:

Check the installation situation of the relevant vehicle type.

3.2. Installation location

The heater may be fitted both in the interior or on the exterior of the vehicle.

If it is installed on the exterior ensure that the heater is fitted in a position where it is protected from splashing water and spray.

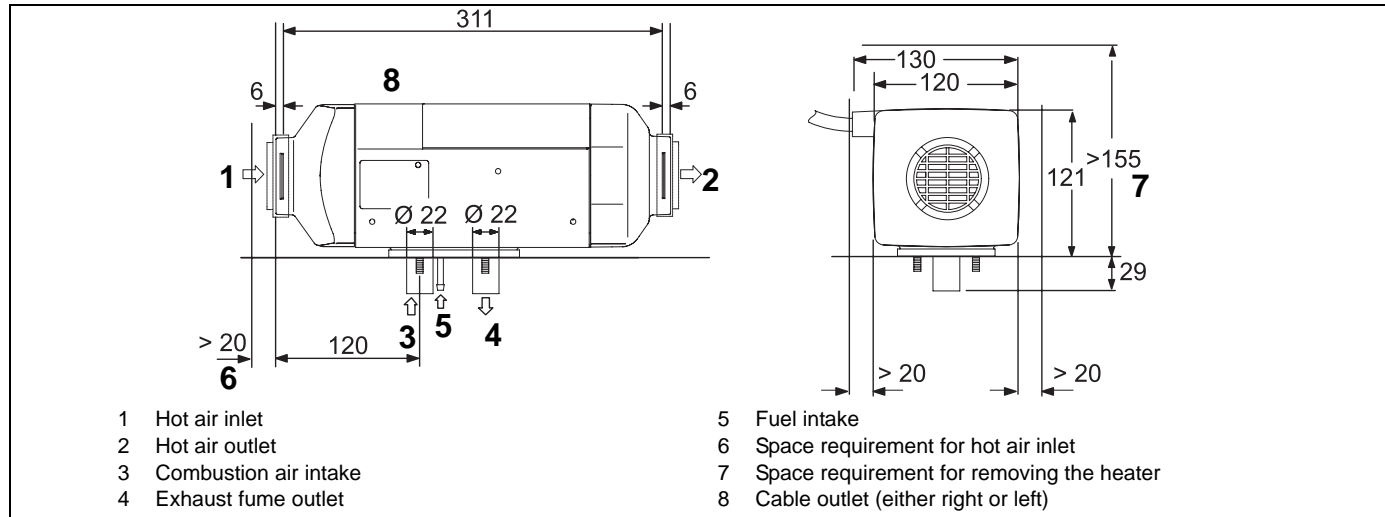

Fig. 1: Dimensions of the heater

The heater must be installed in such a way that no water can ingress into it if the vehicle travels through a water hazard for which that vehicle is licensed.

The openings for the combustion air inlet port, the exhaust outlet port and the fuel pipe must be sealed if the heater is installed in the interior. The seal designed and supplied for this purpose must be used (see Figure 4).

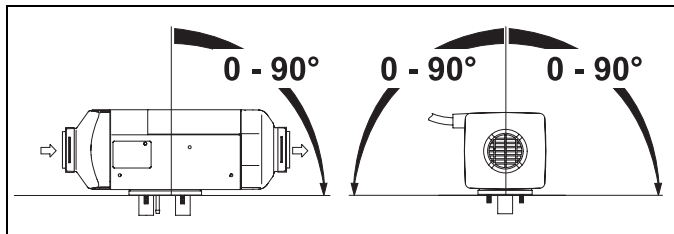

Fig. 2: Recommended installation positions for diesel heaters

We recommend that petrol heaters be installed with the exhaust port pointing vertically downwards.

3.3. To install the heater

The M6 nuts must be tightened with a torque of 6 Nm +1 Nm for installing the Air Top 2000 ST heater.

The installation dimensions and space requirement for service access are shown in the installation drawing (Figure 1). The specified horizontal and axial angles must not be exceeded (Figure 2).

A seal (Figure 4) must be fitted between the heater and the vehicle body. **This seal must be replaced each time the heater is installed.** The support area for the heater foot **must be flat**.

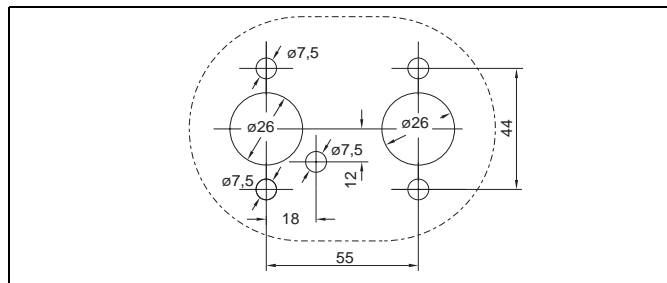

Fig. 3: Hole pattern

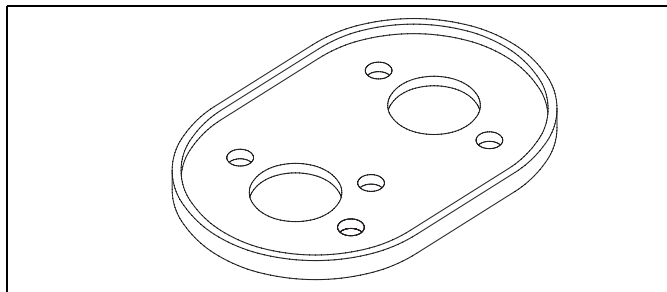

Fig. 4: Seal

A special tools can be purchased from Webasto to drill the holes and, if necessary, smooth the support area. The seal can compensate for unevenness of max. 1 mm.

IMPORTANT

After installation, check that the casing is not in contact with any parts of the vehicle body. A failure to do this may result in the hot air fan blocking.

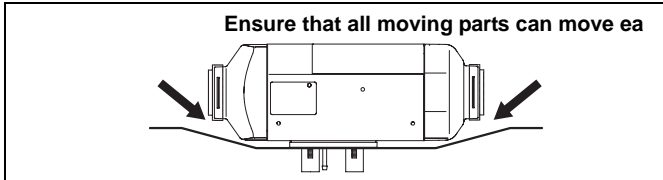

Fig. 5: Installation

4 Factory plate

The model plate must be positioned so that it cannot be damaged and must be clearly legible when the heater is installed (otherwise a duplicate model plate must be used).

Inapplicable years must be erased from the model plate.

5 Installation example

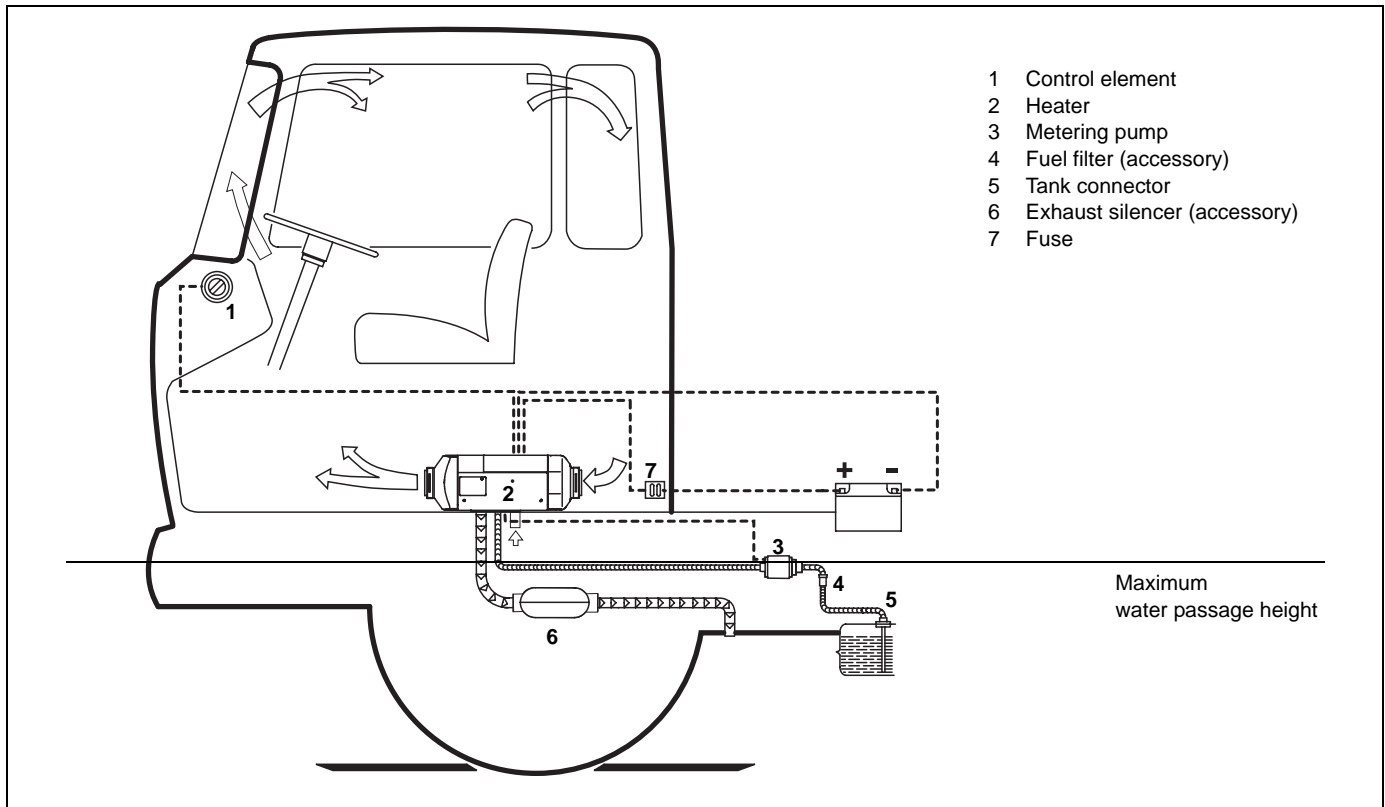

Fig. 6: Installation example for air heater in recirculation mode

6 Hot air system

NOTE:

The heater must not be integrated into the vehicle's air system.

Both recirculation and fresh air modes are possible.

For fresh air mode it must be ensured that the hot air is taken from an area protected from splashing water and spray and in such a way that no water can ingress into the heater if the vehicle travels through a water hazard for which that vehicle is licensed.

NOTE:

For fresh air mode an external temperature sensor must be fitted in the appropriate zone.

Inside the control unit there is a temperature sensor, which operates the heater in the appropriate heat output range in conjunction with the control element depending on the intake temperatures and the position of the setpoint generator. The heat output is controlled such that after the selected interior temperature has been reached quickly, it is then kept at this selected value.

The internal diameter of the main section of the hot air line should be 60 mm.

NOTE:

Only materials that can permanently withstand temperatures of at least 130 °C may be used for the hot air line. The hot air opening is to be positioned in such a way that the air is not blown on to any parts that cannot withstand the heat.

IMPORTANT

In vehicles used to transport people, the air outlet opening is to be directed in such a way that it is at least 20 cm away from all body parts.

Maximum pressure drop between the inlet and outlet side of the hot air line:

Air Top 2000 ST 1.5 hPa

1 hPa corresponds to 1 mbar corresponds to 10mm WC (water column).

The heaters check the internal temperature rise automatically each time they are switched on. If this is above the specified limits, the start is cancelled and error messages F10 is displayed. To ensure that the heater functions stably, the flow resistance of the connected hot air system must be reduced.

The hot air hose must be secured at its connection points.

If the heater is used in recirculation mode without a hot air guide, do not short circuit the hot air flow.

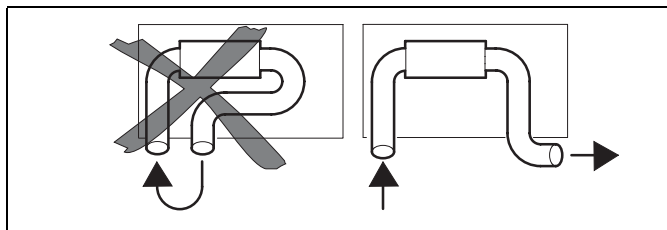

Fig. 7: Hot air inlet and hot air outlet

IMPORTANT

If you use the heater without a hot air inlet hose, the inlet grille supplied with the heater must be used at all times.

NOTE:

The installation must be checked for:

- Air short circuit between the vehicle's heating system and the heater air inlet
- Air short circuit between the heater's air inlet and the heater's air outlet (Figure 7)

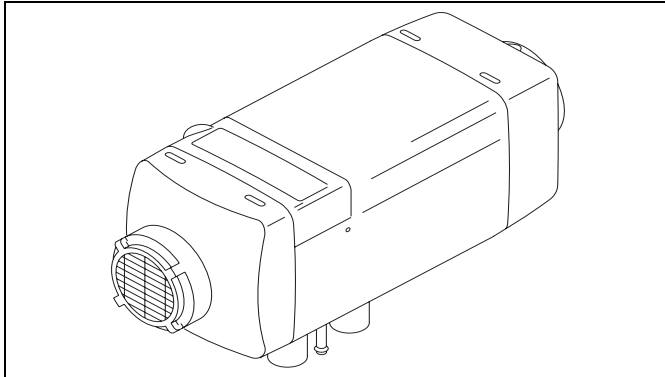

Fig. 8: Hot air inlet with inlet grille

If you use an installation box the air vent must be sealed in such a way that no hot air can get into the installation box.

6.1. External temperature sensor

The installation of an external temperature sensor is recommended if the heater is operated in fresh air mode.

6.1.1. To install the external temperature sensor

The external temperature sensor must be installed at medium height in the passenger cabin on vertical surfaces if possible in the area that requires heating.

The temperature sensor must **not**

- be in the direct current of hot air (from the vehicle's own heating system or the hot air heater).
- be close to heat sources (for example the vehicle's own heating system).
- be placed in direct sunlight (for example on the dashboard).
- be installed behind curtains or the like.

7 Fuel supply

The fuel is taken from the vehicle fuel tank or from a separate fuel tank. The values for the maximum pressure at the fuel extraction point are shown in Figure 9.

Permissible fuel inflow height H (m)	At max. perm. pressure (bar) in fuel line
0.00	0.2
1.00	0.11
2.00	0.03
Maximum fuel intake height S (m)	At max. perm. negative pressure (bar) in the fuel tank
0.00	-0.10
0.50	-0.06
1.00	-0.02

Only for ADR: The statutory regulation of ADR (Accord européen relatif au transport international des marchandises dangereuses par route) governing fuel tanks, part 9 para. 9.2.4.7, must be adhered to.

A sign must be affixed to the fuel filler neck warning that the heater must be switched off before refuelling.

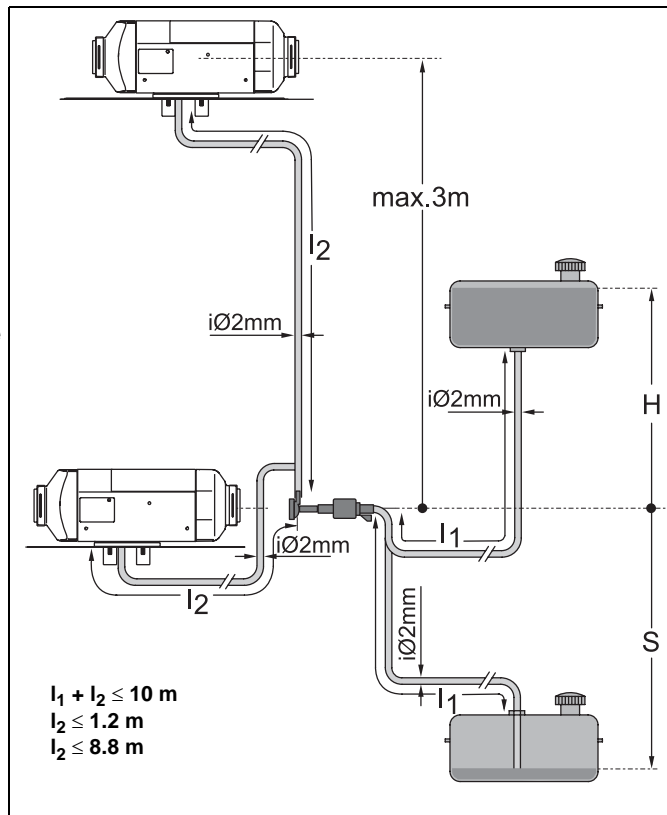

Fig. 9: Fuel supply

7.1. Vehicles with carburettor engines

The fuel may only be extracted using the special Webasto fuel extractor (see Figure 10) as close to the tank as possible. The connect may be made in either the supply or return line, in which case the return line must lead almost to the base of the tank (see Figure 11).

The fuel extractor must be fitted in such a way that any air or gas bubbles are automatically discharged towards the tank (see Figure 10).

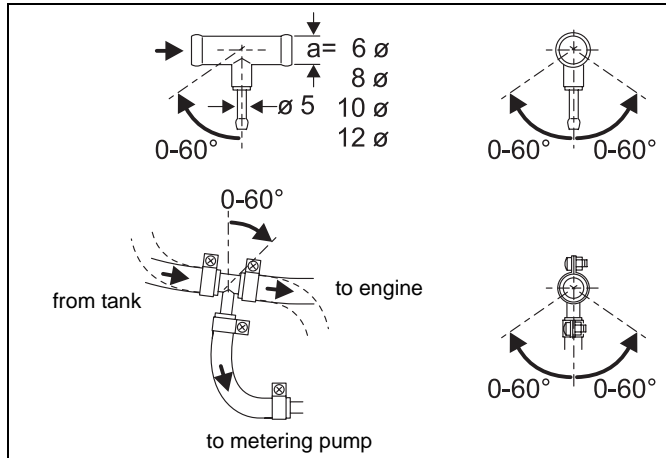

Fig. 10: Webasto fuel extractor

The fuel extractor should not be located near the engine, as gas bubbles may form in the lines on account of heat radiated from the engine. This may cause problems during combustion.

7.2. Vehicles with injection engines

When installing the heater in a vehicle with fuel injection system, it is important to establish whether the fuel pump is located inside or outside the tank.

If the fuel pump is located inside the tank, fuel can only be extracted from the return line using the Webasto fuel extractor (see Figure 10), in which case it must be ensured that the return line continues almost to the bottom of the tank (see Figure 11 for details of the minimum distance from the bottom of the tank). If this is not the case Webasto fuel extractor (see Figure 11, 12 and 13) may be used.

If the fuel pump is installed outside the tank, the fuel connection may also be made between the tank and the fuel pump, again using only the Webasto fuel extractor (see Figure 10).

7.3. Vehicles with diesel engines

The fuel must be taken from the vehicle fuel tank or from a separate tank (see Figs. 10, 11 and 12). This separate fuel pickup precludes any effect of pressure.

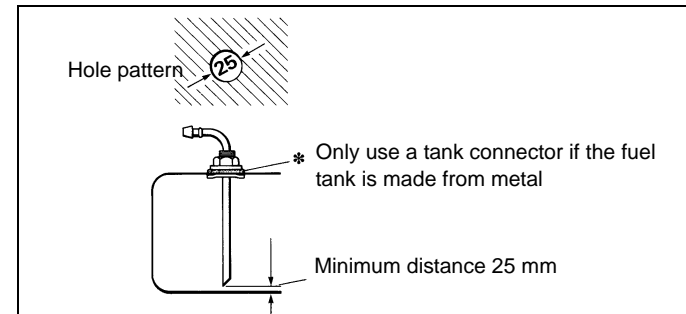

Fig. 11: Webasto tank connector

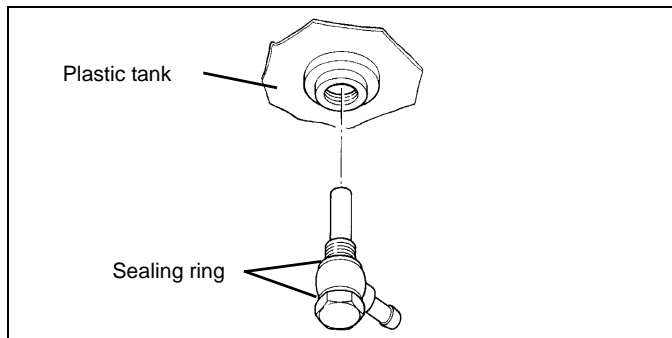

Fig. 12: Fuel pickup from the plastic tank
(Pickup via tank drain screw)

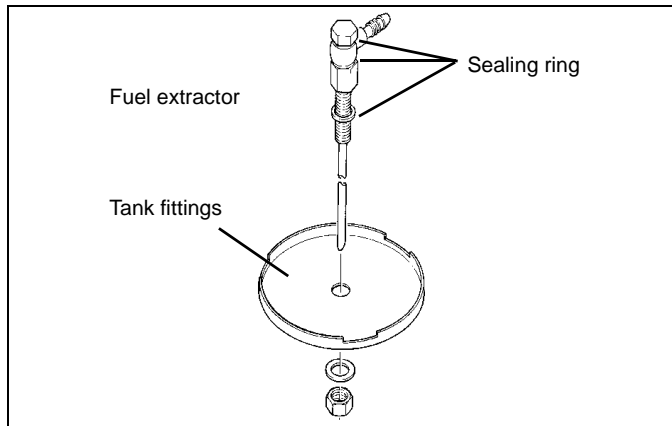

Fig. 13: Fuel pickup from the plastic tank
(Pickup via tank fitting)

NOTE:

The tank fitting must be made from metal!

7.4. Fuel lines

Only steel, copper and plastic lines of plasticised, light and temperature-stabilized PA 11 or PA 12 (e.g. Mecanyl RWTL) pursuant to DIN 73378 may be used for the fuel lines.

Since the lines normally cannot be routed with a constant rising gradient, the internal diameter must not be allowed to exceed a certain size. Air or gas bubbles will accumulate in lines with an internal diameter of more than 4 mm and these will cause malfunctions whilst the heater is operating if the lines sag or are routed downwards. The diameters specified in Figure 9 will ensure that bubbles do not form.

The lines should not be routed downwards from the metering pump to the heater.

Unsupported fuel lines must be secured to prevent them sagging. They must be installed in such a way that they cannot be damaged by flying road chippings and high temperatures (exhaust line).

The fuel lines must be secure at the connections using hose clips to prevent their slipping.

7.4.1. Connecting two pipes with a hose

The correct procedure for connecting fuel lines with hosing is illustrated in Fig. 14.

Ensure that there are no leaks.

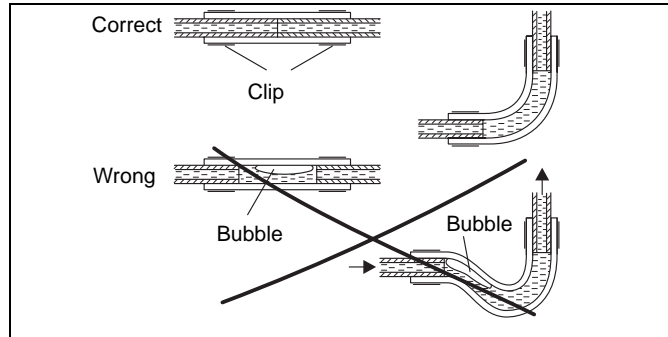

Fig. 14: Pipe / hose connection

7.5. Metering pump

The metering pump is a combined delivery, metering and shutoff system and is subject to specific installation criteria (see Figs. 9 and 15).

Installation location

It is advisable to install the metering pump in a cool place. The maximum ambient temperature must not exceed +20 °C for petrol heaters at any time during operation.

The metering pump and fuel lines must not be installed within range of the radiated heat from hot vehicle parts. A heat shield must be used if necessary.

Air Top 2000 ST

12 V and 24 V - petrol and diesel (with damper)

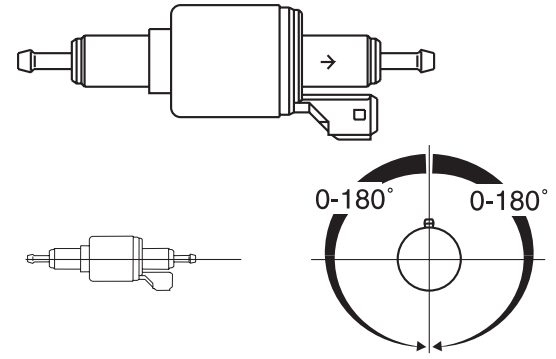

Fig. 15: Metering pump DP2 / DP30.2
Installation position

7.5.1. Installation and attachment

The metering pump must be secured with a vibration-damping mounting. Its installation position is limited as shown in Fig. 15 in order to ensure effective auto-bleeding.

As a result of the risk of corrosion, only genuine Webasto parts may be used for the plug connections between the metering pump and the metering pump wiring harness.

7.6. Fuel filter

Only a Webasto filter, order no. 487 171, is allowed to be used if the fuel is expected to be contaminated. Install vertically if possible, however at least horizontally (check flow direction).

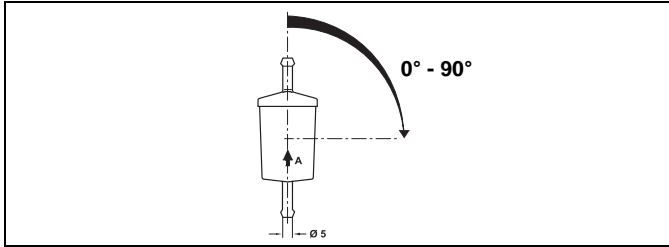

Fig. 16: Fuel filter

8 Combustion air supply

Under no circumstances may the combustion air be taken from areas occupied by people. The combustion air intake opening must not point in the direction of travel. It must be located so that it cannot become clogged with dirt.

NOTE:

An intake silencer must be fitted if the intake hose length is greater than 0.6 m.

NOTE:

The combustion air must be extracted using a combustion air line from a position that is as cool as possible and protected from splashing water. Do not use an exhaust line as the combustion air line since otherwise the metering pump cable from the combustion air inlet port may be damaged.

The combustion air opening must not be under the minimum water drive-through level permitted for the vehicle.

See the statutory regulations for the installation for further regulations.

9 Exhaust pipe

Rigid pipes of unalloyed or alloyed steel with a minimum wall thickness of 1.0 mm or flexible piping of alloyed steel only must be used as exhaust line.

The exhaust pipe is secured to the heater using a clamping collar, for example. See the statutory regulations for other requirements.

The exhaust silencer should ideally be installed near the heater. The heater may also be operated without a silencer.

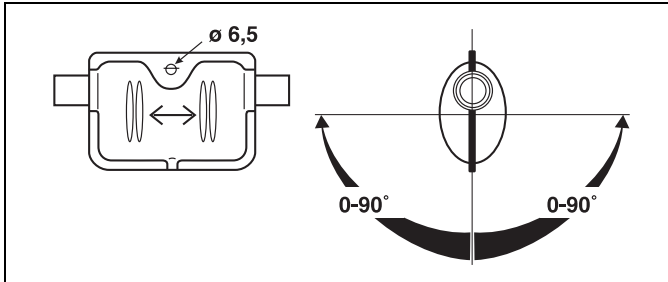

Fig. 17: Exhaust silencer
Arbitrary flow direction

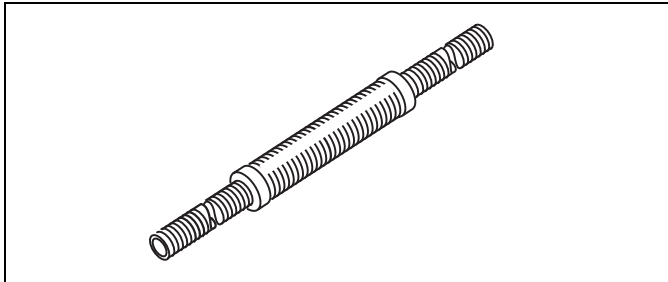

Fig. 18: Exhaust silencer for boat applications
Flow direction and installation position arbitrary

10 Combustion air inlet and exhaust lines

Both lines are to be installed falling away from the heater. If this is not possible, a condensate drain hole with a diameter of 4 mm must be made at its lowest point.

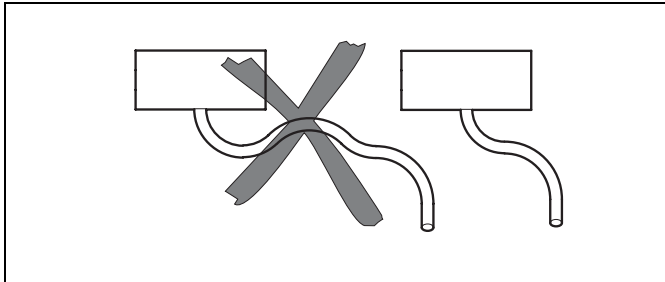

Fig. 19: Prevent the formation of condensate

The lines must not point to the front of the vehicle.

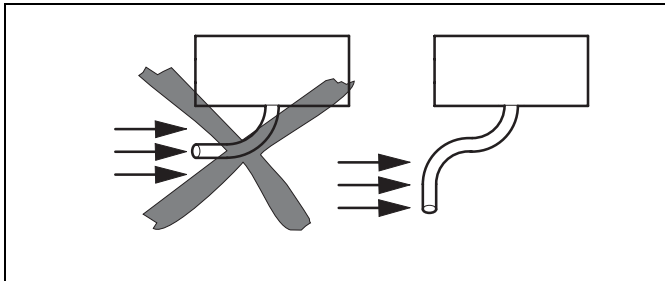

Fig. 20: The lines must not end pointing towards the front of the vehicle

The lines must be located so that they cannot become clogged with dirt.

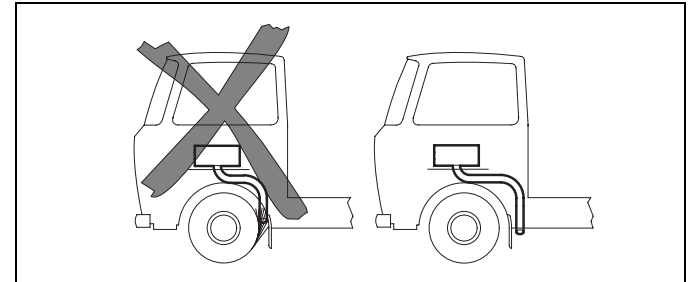

Fig. 21: Avoid the lines becoming clogged with dirt

IMPORTANT

If the exhaust pipe ends is other than as shown in the Figure 22 it will pose a fire risk.

Length of the combustion air inlet and exhaust lines in total:

with silencer: max. 2.0 m

without silencer: max. 5.0 m

NOTE:

If the exhaust line is over 2 m in length the lines must be insulated (to prevent falling below the dewpoint)

Internal diameter of the lines:

Combustion air line: 22 mm

Exhaust line (metal): 22 mm

Minimum bending radius: 50 mm

Total bends:

Combustion air line: max. 270°

Exhaust line: max. 270°.

An attachment is required no further than 150 mm from the end of the exhaust pipe to ensure that the angle of $90^\circ \pm 10^\circ$ is achieved

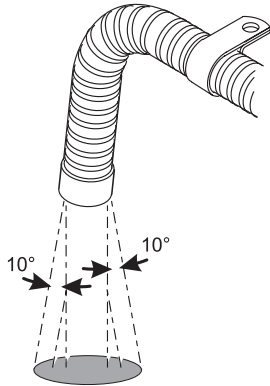

Discharge direction almost vertical $90^\circ \pm 10^\circ$

Fig. 22: Exhaust pipe opening

Installation position

Only for ADR: The statutory regulation of ADR (Accord européen relatif au transport international des marchandises dangereuses par route) governing the routing of the exhaust line, part 9 para. 9.2.4.7, must be adhered to.

11 Electrical connections

All the cables that are not required must be insulated.

NOTE:

If the combination timer is used, a touch-sensitive switch may be installed in the sleeping section to act as a remote control and improved convenience. The connections must be made as shown in the circuit diagrams in Figure 32.

The electrical connection is made as shown in the system circuit diagram (Figures 30, 31, 32 and 33).

11.1. Connection for installing the heater in a hazchem vehicle (ADR)

To install the Air Top 2000 ST D heater in hazchem vehicles, the requirements of ADR/RID part 9 para. 9.2.4.7 – Combustion heating systems, must also be satisfied. The electrical connection is made as shown in the circuit diagram in Figure 33 or 32.

On vehicles without a power take-off the electrical connection must be made as shown in the system wiring diagram in Figure33.

NOTE:

The switch S4 must be installed in such a way that a positive potential is connected to appropriate input of the control module when a pumping device is switched on.

IMPORTANT

All ADR functions are ineffective if there is no earth at control unit input X11/2 when the system is switched on.

The control unit continues to run briefly for 40 seconds and then switches to "fault lock-out" operating mode when a positive voltage is connected to control unit input X11/2 (auxiliary power take-off on) or the engine is switched off.

IMPORTANT

In accordance with the regulations of the act governing the road/rail haulage of hazardous materials, heaters are only allowed to be taken into service with a special manually operated switch fitted in the cab. If the system is equipped with a combination timer, ensure that contact 4 on the combination timer remains free. The heater can then only be taken into service using the immediate heat button. The use of other timers in ADR vehicles is not permitted.

11.2. Heater connection

To connect the wiring harness, remove the control unit cover on the heater and connected the wiring harness plug to the control unit.

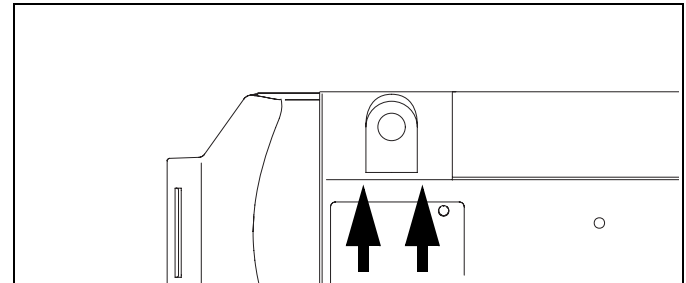

Fig. 23: To remove the control unit cover

NOTE:

Raise the control unit cover on both sides using a blunt blade (Figure 23 arrows).

Before using the heater for the first time fit the control unit cover to prevent the illegal escape of hot air (heater overheating).

The cable passage can be placed at either the left or right side.

To ensure that the cable passage in the control unit cover seals perfectly, the cable grommet is to be adjusted appropriately on the wiring harness.

11.3. Supply voltage connection

Ideally from the vehicle's central electrical system.

An additional blade terminal fuse holder is to be fitted to protect the heater (supplied with the heater). The fuse holder may only be installed in the interior of the vehicle.

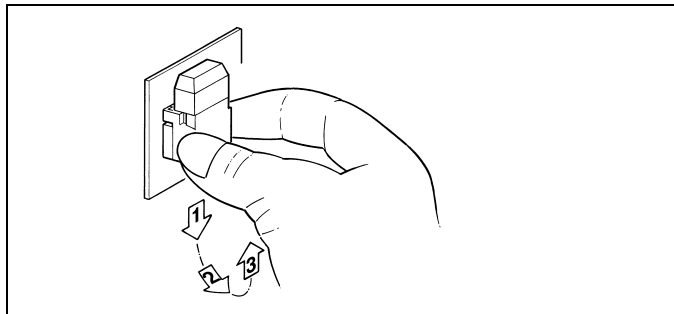

Fig. 24: Remove the fastening plate on the fuse holder

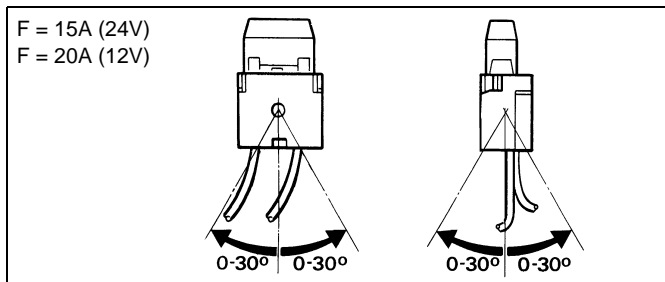

Fig. 25: Fuse holder, installation position

11.4. Control element connection

The wiring harness is prepared for connection to the control element. Simply pull on connector housing to unplug the connector. The connector housing can be locked (self-locking action) by simply pulling on the wiring harness.

NOTE:

The fibre optic cable must be in contact with the rotary knob

NOTE:

As an option an external temperature sensor may be installed in the passenger cabin (see page 49).

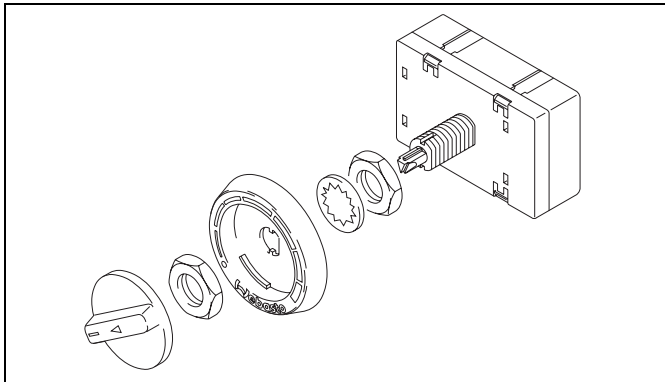

Fig. 26: Control element

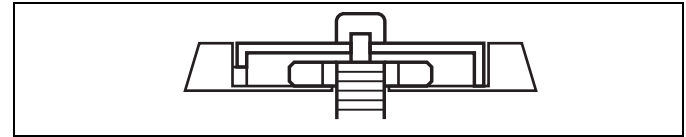

Fig. 27: Installation of the control element

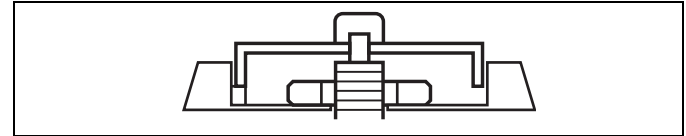

Fig. 28: Installation of the control element (incorrect)

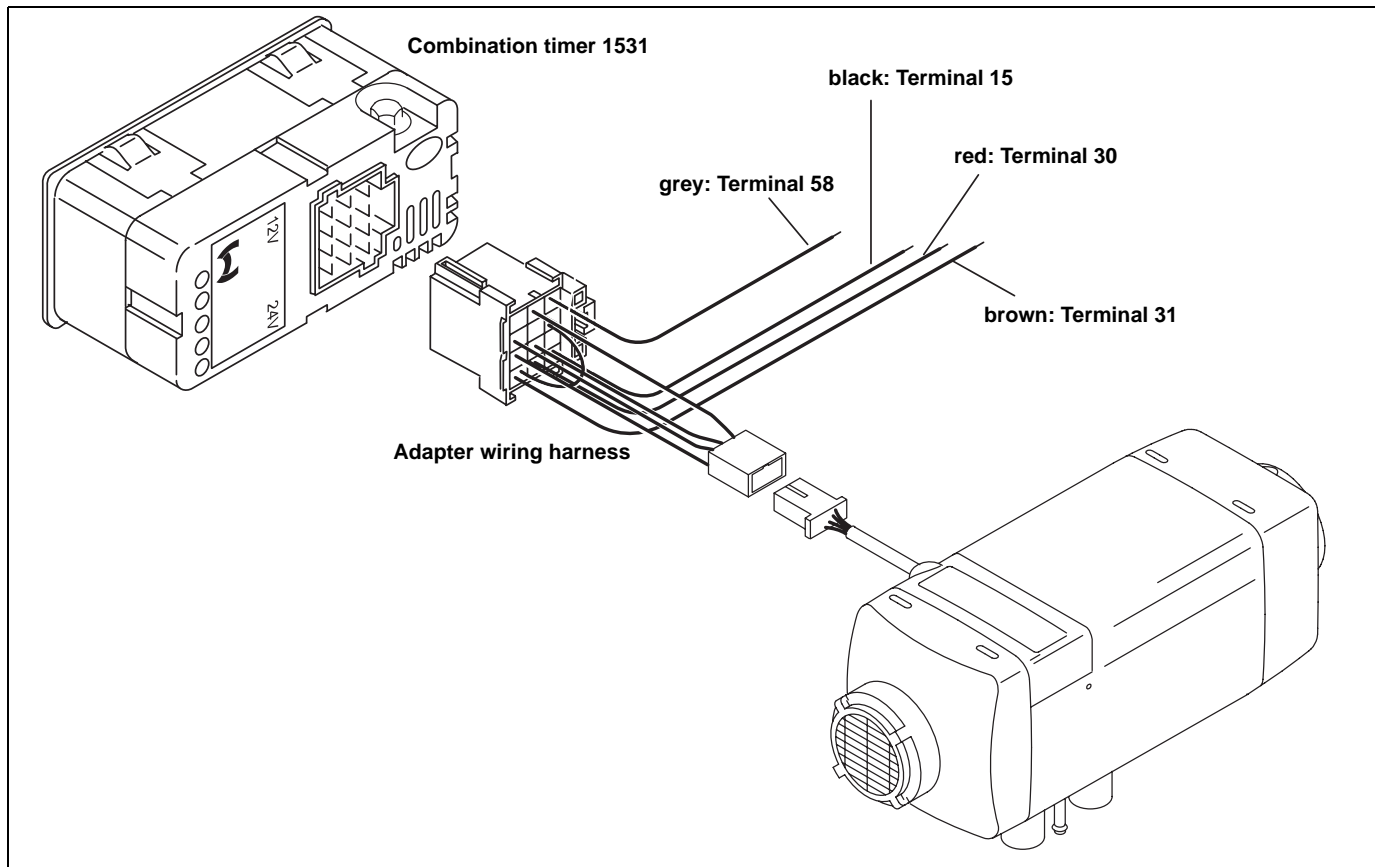

Fig. 29: Air Top 2000 ST with combination timer connection diagram

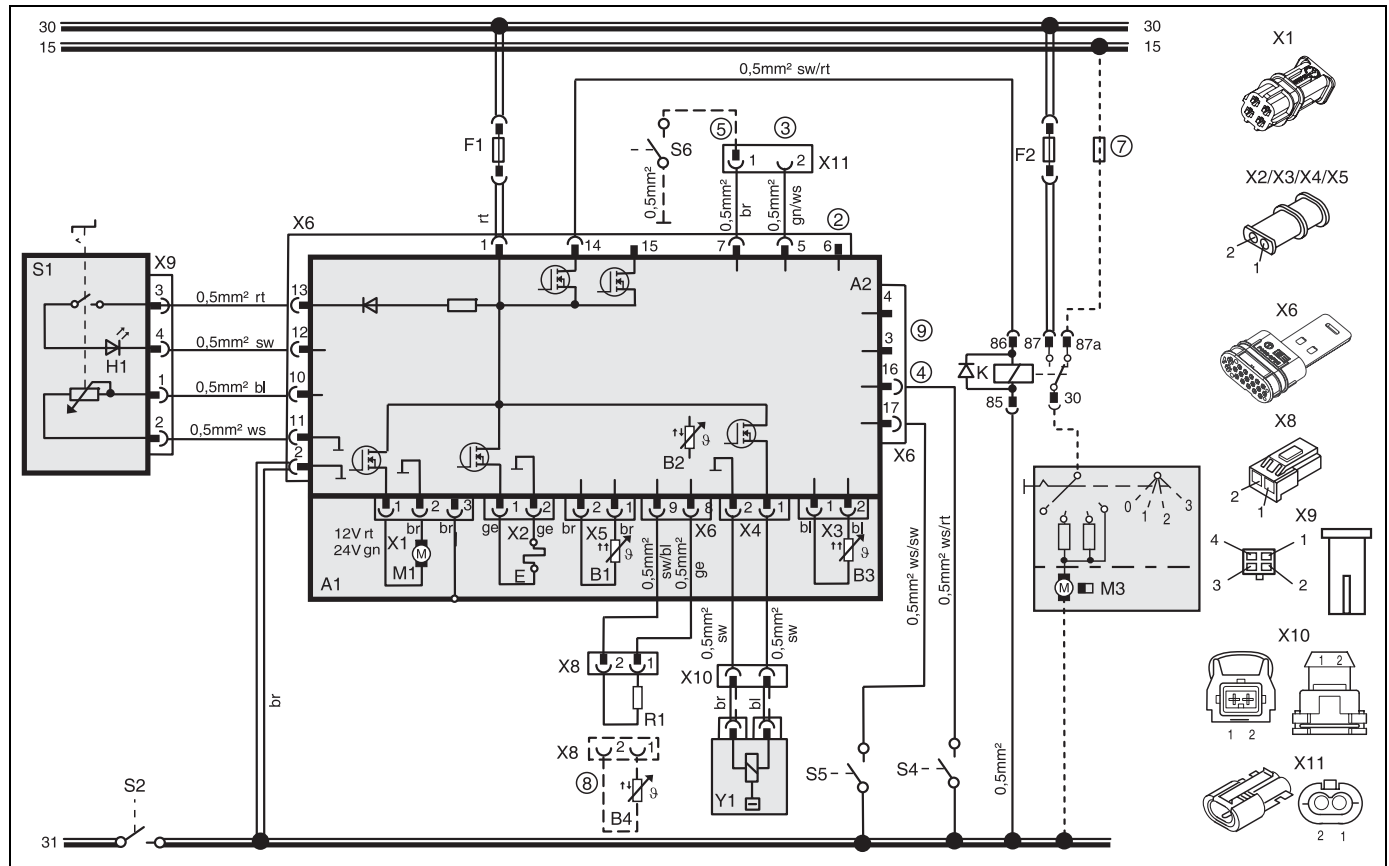

Fig. 30: System wiring diagram for the Air Top 2000 ST, 12V/24V with control element and vehicle fan, for legend see pages 67 and 68

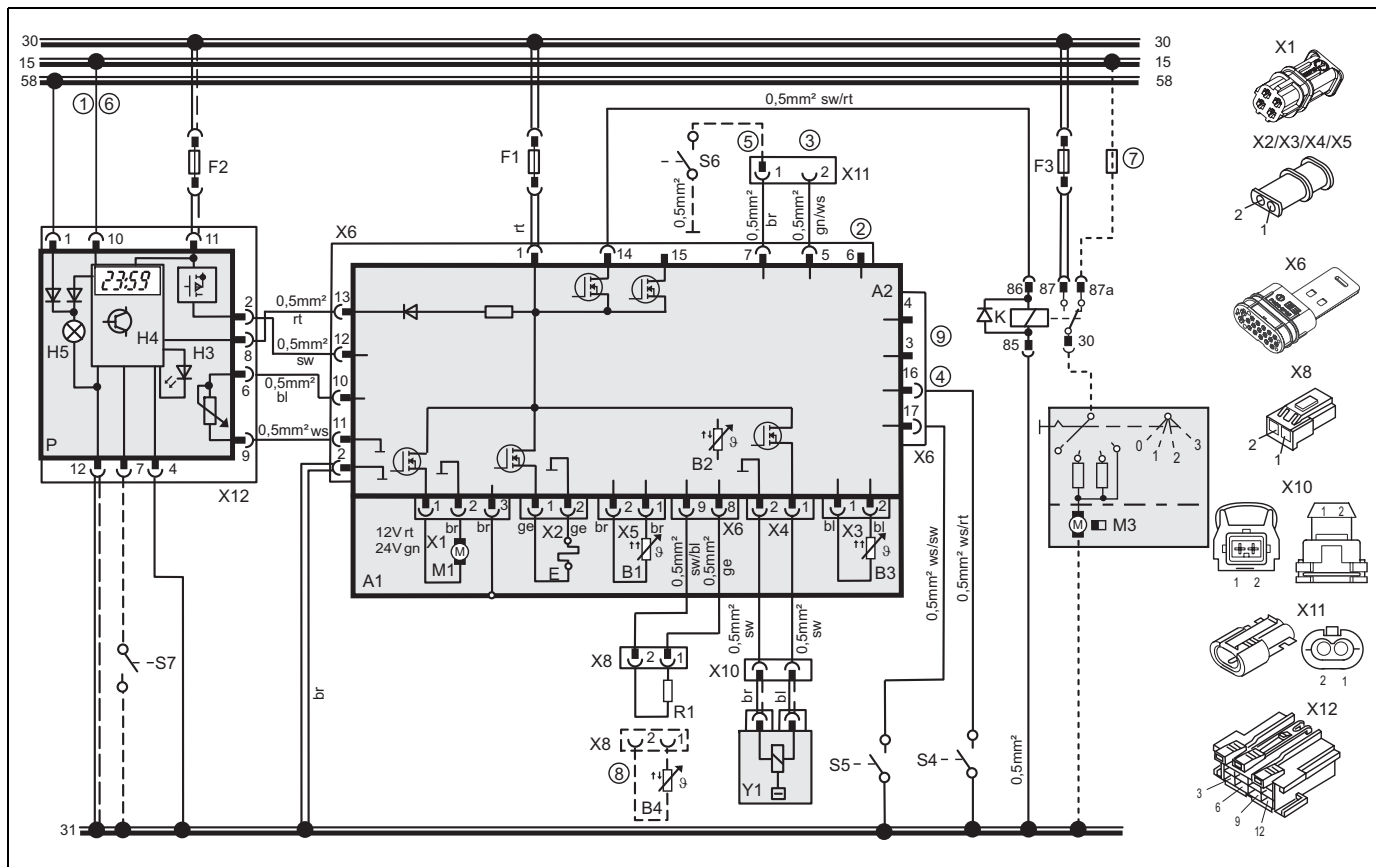

Fig. 31: System wiring diagram for the Air Top 2000 ST, 12V/24V with combination timer and vehicle fan, for legend see pages 67 and 68

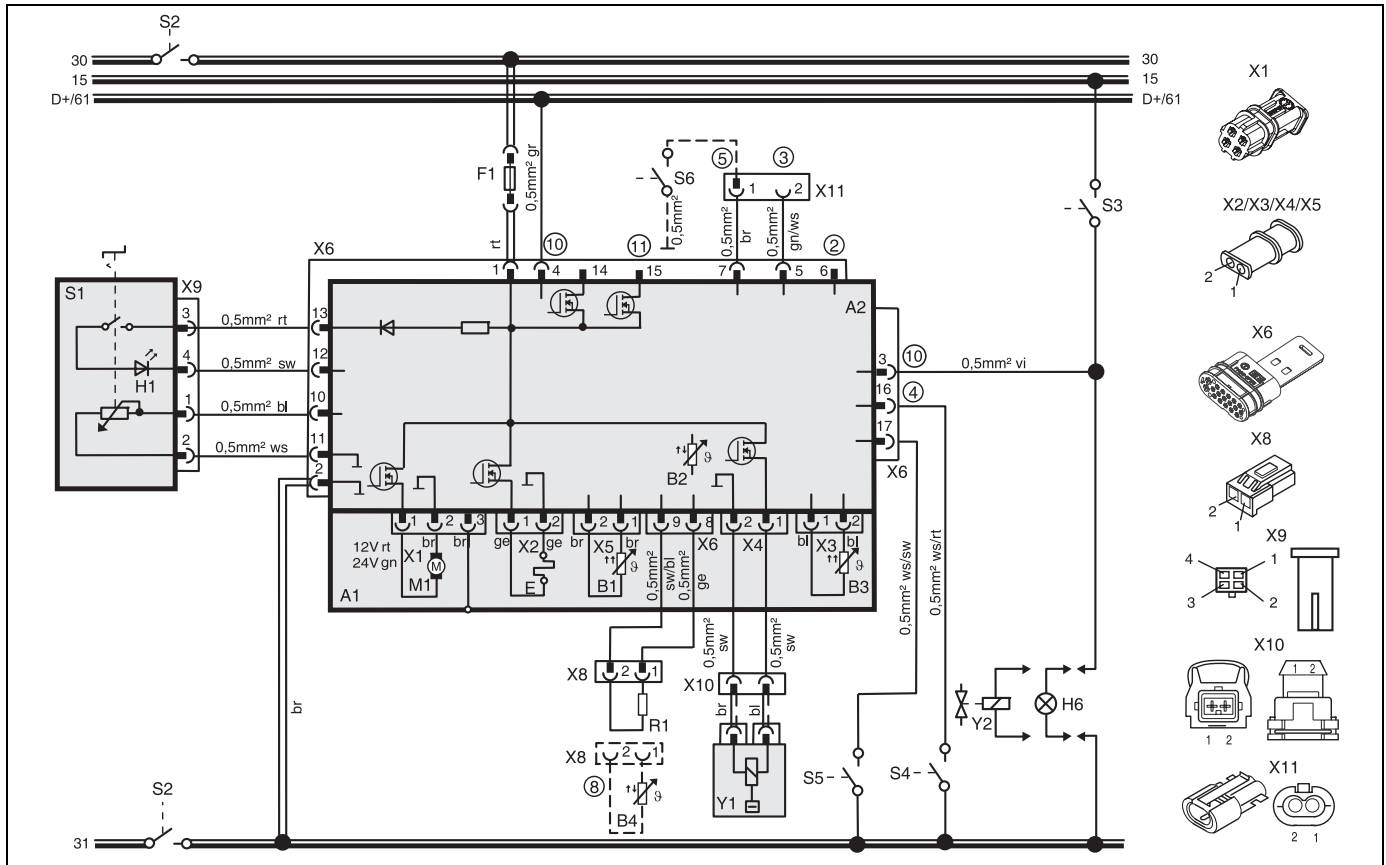

Fig. 32: System wiring diagram for the Air Top 2000 ST D, 24V ADR operation with control element, for legend see pages 67 and 68

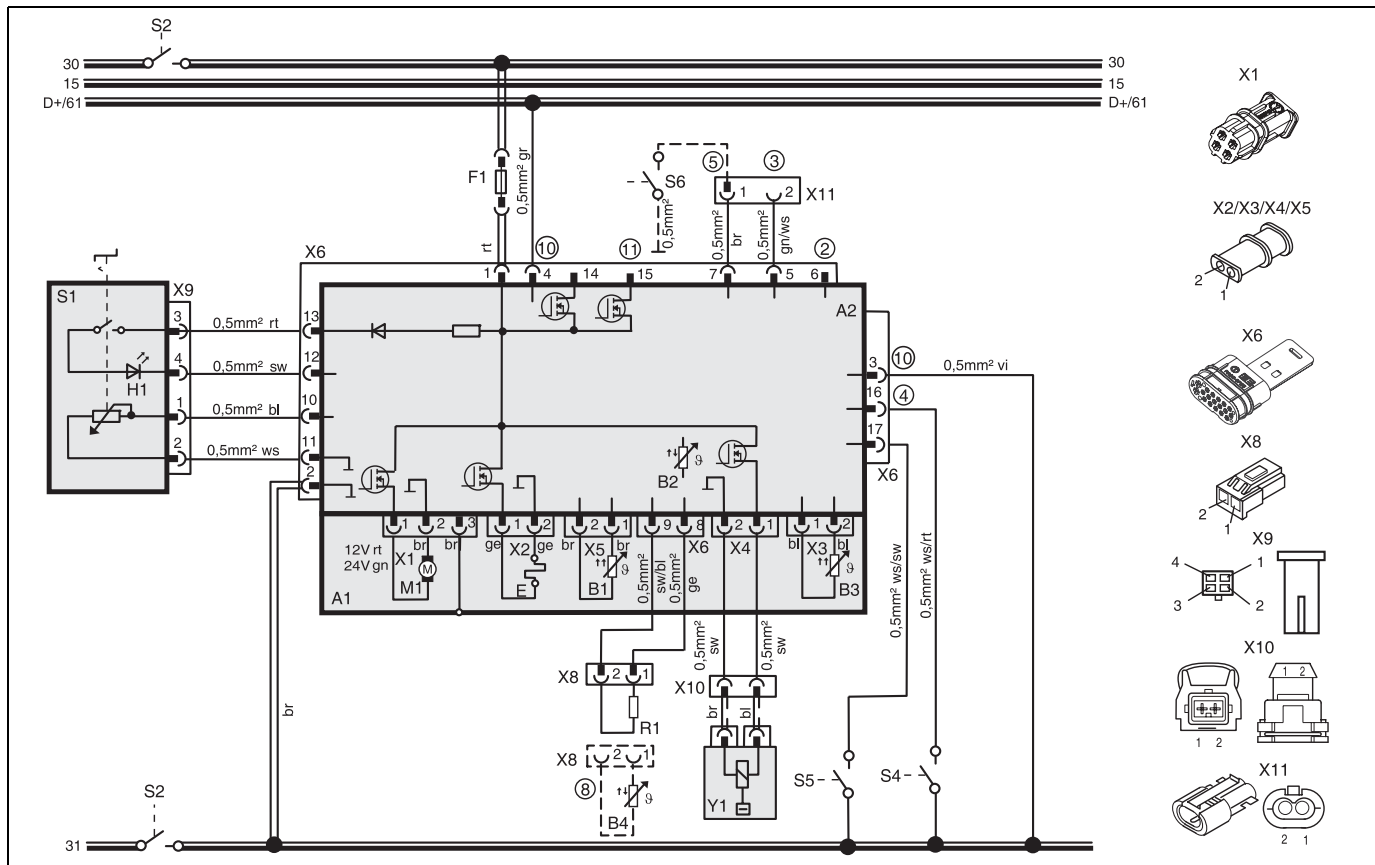



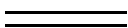



Fig. 33: System wiring diagram for the Air Top 2000 ST D, 24V ADR operation with control element without power take-off, for legend see pages 67 and 68

12 Legend for circuit diagrams:

- ① With positive from terminal (15/75) to connection 10:
Permanent operation for immediate heat as long as the ignition is switched on
Without positive at connection 10:
Heating time is variably programmable (10 min to 120 min), default setting 120 min
- ② Diagnostic K cable
- ③ W bus
- ④ Inputpin (pin 16/plug X6, cable colour on wiring harness: ws/rt):
„Ventilation“ (fan speed depends on the position of the control element)
- ⑤ CO₂ adjustment (see workshop manual)
- ⑥ **NOTE:**
If the connection is made to terminal 30, permanent heating is possible when the ignition is switched off!
In this case no connection must be made to terminal 15/75.
- ⑦ Fuse installed in vehicle
- ⑧ If an external temperature sensor (B4) is used, resistor R1 must be replaced by the temperature sensor (B4).
- ⑨ Connection for ADR vehicles only
- ⑩ **NOTE:**
Grey and violet cables required for ADR function
- ⑪ Signal for battery isolation switch
The relay input (if available) of the isolation switch (S2) must be connected to the control unit Pin 15/Plug X6.

Cable cross-sections		
	< 7.5 m	7.5 - 15 m
	0.75 mm ²	1.0 mm ²
	1.0 mm ²	1.5 mm ²
	1.5 mm ²	2.5 mm ²
	2.5 mm ²	4.0 mm ²
	4.0 mm ²	6.0 mm ²

Cable colours	
bl	blue
br	brown
ge	yellow
gn	green
gr	grey
or	orange
rt	red
sw	black
vi	violet
ws	white

Legend for circuit diagrams:

Air Top 2000 ST

Item	Description	Comment
A1	Heater	Air Top 2000 ST
A2	Control module	
B1	Flame sensor	for petrol heater only
B2	Temperature sensor	internal
B3	Overheating sensor	Overheating guard
B4	Temperature sensor	External
E	Glow plug	
F1	Fuse 24 V 15A/12V 20A	Flat fuse SAE J 1284
F2	Fuse 20 A	Flat fuse SAE J 1284
F3	Fuse max. 15A	Flat fuse SAE J 1284
H1	LED, green (in item S1)	Indicator
H3	LED red (in item P)	Light in immediate heat button, ready indicator, Switch-on indicator
H4	Heating symbol in the display (in item P)	Indicator
H5	Light (in item P)	Display and button lights
H6	Light (at least 1.2 W)	Switch-on indicator pumping device
K	Relay with free-wheeling diode	for vehicle fan
M1	Motor	Combustion and hot air fan
M3	Motor	Vehicle fan
P	Combination timer (1531)	Timer and setpoint generator
R1	Resistor 620 Ω	With internal temperature sensor only
S1	Control element	Setpoint generator switch
S2	1 or 2-pin disconnecting switch	Emergency Stop switch
S3	Switch	On and for pumping device

Item	Description	Comment
S4	Switch	Ventilation
S5	Switch	Flashover sensor
S6	Switch	CO ₂ setting
S7	Momentary-contact switch	Immediate heat button remote control
S8	Battery isolation switch	
V1	Diode	
V2	Diode	
X1	Plug connector, 2-pin	to item A2 (ST B)
X2	Plug connector, 2-pin	to item A2 (ST V)
X3	Plug connector, 2-pin	to item A2 (ST U)
X4	Plug connector, 2-pin	to item A2 (ST Z)
X5	Plug connector, 2-pin	to item A2 (ST Y)
X6	Plug connector, 2-pin	to item A2 (ST X)
X7	12-pin plug connection	to item A2 (ST1)
X8	Plug connector, 2-pin	
X9	Plug connector, 4-pin	to item S1
X10	Plug connector, 2-pin	to item Y1
X11	Plug connector, 2-pin	
X12	12-pin plug connection	to item P
Y1	Metering pump	
Y2	Solenoid valve	for pumping device

13 Initial start-up

After you have installed the heater, bleed the fuel supply system carefully.

NOTE:

As a result of the low fuel consumption the heater must be switched on several times to fill the fuel line.

Conduct a trial of the heater to check all the connections for leaks and to ensure that they are secure. If the heater suffers a fault during operation, the fault must be located and remedied.

14 Fault lock-out

The control unit has identified errors on individual heater components and faults during the operation.

The heater is shut down (fault lock-out) if:

- No or incorrect start
- Temperature sensor defective
- Overheating sensor interrupt or short circuit
- Overheating sensor installed incorrectly
- Glow plug interrupt or short circuit
- Fan motor overload or blocked or short circuit or interrupt
- Error in the metering pump or overheating guard circuit (start phase only)
- Undervoltage less than 10.5 V or overvoltage greater than 16 V and for longer than 20 seconds (on 12 V heater)
- Undervoltage less than 21 V or overvoltage greater than 32 V and for longer than 20 seconds (on 24 V heater)
- Control unit defective
- Overheating
- Flame monitor defective (petrol heater)

The fuel supply is stopped if the heater overheats.

The heater continues to run in the same way as if it is switched off manually.

After it stops the control unit will be set to fault lock-out.

The overheating is indicated by the indicator flashing 10 times.

Rectify the cause of the fault.

To reset the fault switch the heater on and off briefly (at least 2 seconds).

If serious malfunctions such as overheating or failure to start reoccur, the heater is locked (F 12) and can be put back into service by disconnecting the power supply with the heater switched on (e.g. by removing and reinserting fuse).

14.1. Error code output

NOTE:

The error code is output if the heater is fitted with a control element after an error has occurred by the switch-on indicator/error code indicator flashing. After 5 seconds of fast flashing, the error code will be output by a sequence of long flash pulses, the number of flashes is shown in the table below.

If the heater is fitted with a combination timer, an error message will appear on the display of the timer after a fault occurs: If the control element is used the error number is indicated by the indicator light flashing:

- F 00 Control unit error / incorrect data set / customer bus defective
- F 01 No start (after 2 attempts to start) / no flame formation
- F 02 Flame failure (repeated > 3)
- F 03 Undervoltage or overvoltage
- F 04 Premature flame recognition
- F 05 Flame monitor (petrol heater) interrupt or short circuit
- F 06 Temperature sensor interrupt or short circuit
- F 07 Metering pump interrupt or pump short circuit
- F 08 Fan motor interrupt or short circuit or overload or blocked
- F 09 Glow plug interrupt or short circuit
- F 10 Overheating: Resulting in permanent heater fault lock-out
- F 11 Overheating sensor interrupt or short circuit
- F 12 Heater lock-out
- F 14 Overheating sensor incorrect position
- F 15 Setpoint generator interrupt

15 Technical data

Except where limit values are specified, the technical data refer to the usual heater tolerances of $\pm 10\%$ at an ambient temperature of $+20\text{ }^{\circ}\text{C}$ and at the rated voltage and in rated conditions.

15.1. Electrical components:

Control unit, motor, metering pump, lamp in the timer and glow plug / flame monitor are designed for either 12 V or 24 V.

The timer, overheating sensor and temperature sensor component are not dependent on voltage.

15.2. Fuel for Air Top 2000 ST B (petrol):

The fuel specified by the manufacturer must be used.

15.3. Fuel for Air Top 2000 ST D (diesel/ EL heating oil):

The diesel fuel specified by the manufacturer must be used. Class EL heating oil (not L heating oil) may also be used as long as it complies to the normal quality available on the German market pursuant to DIN 51603.

We know of no negative influences due to additives.

If fuel is extracted from the vehicle's tank, follow the additive instructions issued by the vehicle manufacturer.

If you change to low-temperature fuel, the heater must be operated for approx. 15 minutes so that the fuel system is filled with the new fuel.

The Air Top 2000 ST D heater is also licensed for use with PME (bio-diesel), which complies with DIN EN 14214.

Heater	Operation	Air Top 2000 ST B	Air Top 2000 ST D
Type test permit	EMC heater	e1*72/245*95/54*1085*00 e1*2001/56*0022*00 E1*R122 00 0216*--	
Model		Air heater with evaporator burner	
Heat output	Control range	1.0 - 2.0 kW	0.9 - 2.0 kW
Fuel		Petrol	Diesel/PME
Fuel consumption	Control range	0.1 .. 0.2 kg/h (0.14 .. 0.27 l/h)	0.1 .. 0.21 kg/h (0.12 .. 0.24 l/h)
Rated voltage		12 V	12/24 V
Operating voltage range		10.5 - 16 V	10.5 - 16 / 21 - 32 Volt
Rated power consumption	Control range	14 - 29 W	
Max. ambient temperature: Heater: - Operation - Storage Metering pump: - Operation - Storage Control Panel: - Operation - Storage		-40... + 40 °C -40... + 85 °C -40... + 20 °C -40... + 85 °C -40... + 75 °C -40... + 85 °C	
Maximum combustion air inlet temperature		-40... + 20 °C	
Adjustment range for interior temperature	Control range	+5... + 35 °C	
Delivery rate for hot air at fan speed	against 0.5 mbar	max. 93 m ³ /h at 4750 rpm	
CO ₂ in exhaust gas (permitted function range)	1 kW 2 kW	5.0 ... 8.0 9.0 ... 12.5	5.0 ... 8.0 9.0 ... 12.5
Heater dimensions		Length 311 ± 2 mm Width 120 ± 1 mm Height 121 ± 1 mm	
Weight		2.6 kg	

16 Version

Air Top 2000 ST-B (petrol)

Air heater for petrol (12 V)

Air Top 2000 ST-D (diesel)

Air heater for diesel/EL heating oil (12 or 24 V)

17 Drilling template

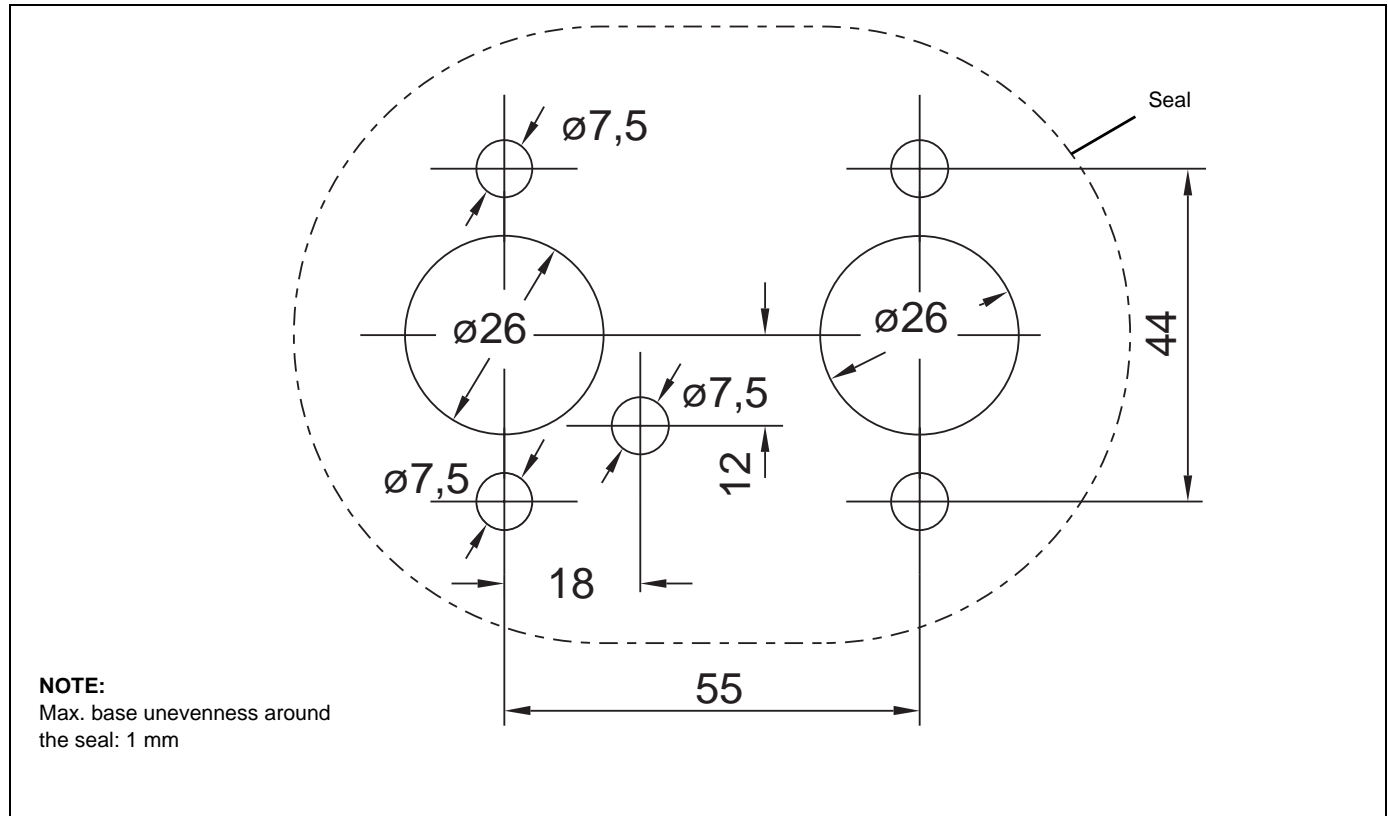

Fig. 34: Drilling template

Die Betriebsanweisung vor Inbetriebnahme des Heizgerätes unbedingt lesen.

The Operating Instructions must be read before attempting to start up the heater.

De gebruiksaanwijzing moet beslist voor inbedrijfstelling van het verwarmingstoestel gelezen worden.

Im Fall einer mehrsprachigen Version ist Deutsch verbindlich.
In multilingual versions the German language is binding.
Bij een meertalige versie is de Duitse versie bindend.

Webasto AG

Kraillingen Strasse 5

82131 Stockdorf

GERMANY

Tel: +49 (0)89 85794 - 0

Fax: +49 (0)89 85794 - 448

<http://dealers.webasto.com>

Änderungen vorbehalten

Subject to modification

Veranderingen voorbehouden

© 2007 All Rights Reserved