

Compact Cooler 4 E

Roof-mounted air-conditioning system

The intelligent and practical solution

For your mobile workplace

The CC4E roof-mounted air-conditioning system is particularly suitable for vehicles and machinery where refrigerant lines may interfere with operations, such as cranes, agricultural machinery, earth-moving equipment and service vehicles.

All major components are contained in the externally mounted unit, with air distribution being controlled via an air-distribution panel, mounted on the underside of the roof mount inside the cabin.

The system is pre-filled with Refrigerant (R134a). Once the unit has been roof-mounted and the internal air-distribution panel has been affixed, a simple connection to the on-board 24V power supply via cable harness completes the installation.

The CC4E is equipped with a protective circuit to prevent total battery exhaustion. The system disables itself automatically if the power supply drops below 20V for more than 10 seconds.

A 'soft-start' function prevents current peaks affecting the on-board power supply during start up of the system. An additional current overload protector triggers automatic shut-down of the system should current peaks in excess of 80A occur.



approx. 12,000 BTU Cooling Capacity

Optional:

- Set-point potentiometer with knob
Electric motor automatically shuts down when set temperature is reached and restarts when a subsequent temperature increase exceeds 2° C

CC4E Components:

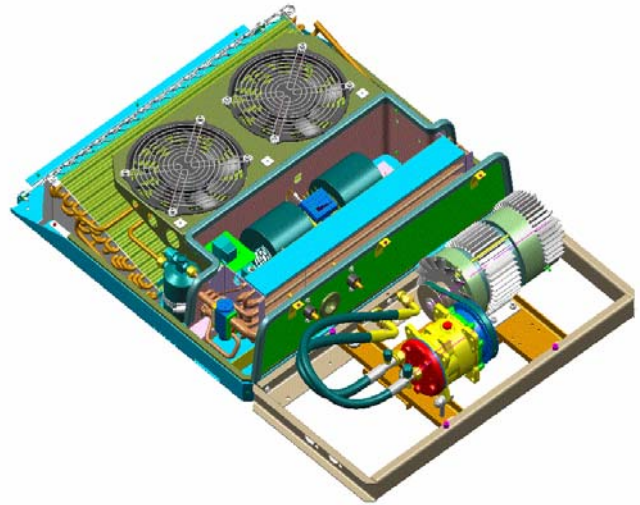
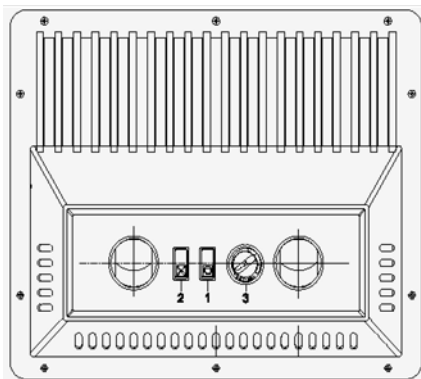
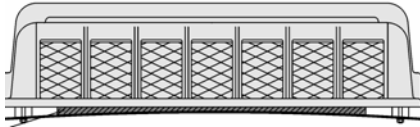
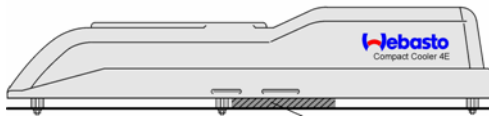

CC4E Roof Mount Components:

- Baseplate – load bearing structural element
- Radial Fan
- Receiver-drier with view glass and pressure switch
- Condenser
- Evaporator with mist separator
- Expansion valve
- Anti-icing switch
- Screw connections
- Relay and holder for blade-type fuses
- Cable harness with grommet
- Axial fan
- Electric motor
- Compressor
- Refrigerant hoses
- Connecting pins

Technical specifications:

Unit	Cooling power (kW/BTU)	Max. total power consumption (A)	Dimensions L x W x H (mm)	Weight (kg)	Nominal voltage (V)	Refrigerant (CFC-free)
CC4E/ES	3.5/12,000	68	1100 x 774 x 215	55	24	R134a

Webasto - Comfort in Mobility



Webasto Product Australia Pty Ltd
 Global Comfort Solutions
 423-427 The Boulevard
 Kirrawee DC 2232
 Australia
 Phone: +61 (0)2 8536 4800
 Fax: +61 (0)2 8536 4899
 info@webasto.com.au

Advice · Installation · Service